

**TO-252-2L Plastic-Encapsulate Regulators**

**CJ78D05** Three-terminal positive voltage regulator

**FEATURES**

- Maximum output current  
 $I_{OM}$ : 1 A
- Output voltage  
 $V_O$ : 5V
- Continuous total dissipation  
 $P_D$ : 1.25 W

TO-252-2L

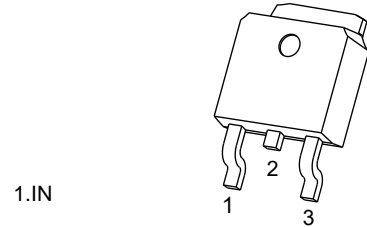

- 1.IN
- 2.GND
- 3.OUT

**ABSOLUTE MAXIMUM RATINGS (Operating temperature range applies unless otherwise specified)**

| Parameter                                   | Symbol          | Value    | Unit          |
|---|-----------------|----------|---------------|
| Input Voltage                               | $V_i$           | 35       | V             |
| Thermal Resistance from Junction to Ambient | $R_{\theta JA}$ | 100      | $^{\circ}C/W$ |
| Operating Junction Temperature              | $T_J$           | 150      | $^{\circ}C$   |
| Operating Temperature                       | $T_{OPR}$       | -40~+125 | $^{\circ}C$   |
| Storage Temperature Range                   | $T_{STG}$       | -65~+150 | $^{\circ}C$   |

**ELECTRICAL CHARACTERISTICS AT SPECIFIED VIRTUAL JUNCTION TEMPERATURE ( $V_i=10V, I_o=500mA, C_i=0.33\mu F, C_o=0.1\mu F$ , unless otherwise specified)**

| Parameter                | Symbol                | Test conditions                            | Min  | Typ  | Max  | Unit           |
|--------------------------|-----------------------|--|------|------|------|----------------|
| Output voltage           | $V_o$                 | $T_J=25^{\circ}C$                          | 4.85 | 5.0  | 5.15 | V              |
|                          |                       | $8V \leq V_i \leq 20V, I_o=5mA-1A$         | 4.75 | 5.0  | 5.25 | V              |
| Line regulation          | $\Delta V_o$          | $7.5V \leq V_i \leq 25V, T_J=25^{\circ}C$  |      |      | 50   | mV             |
|                          |                       | $8V \leq V_i \leq 12V, T_J=25^{\circ}C$    |      |      | 50   | mV             |
| Load Regulation          | $\Delta V_o$          | $I_o=5mA-1A, T_J=25^{\circ}C$              |      |      | 100  | mV             |
|                          |                       | $I_o=250mA-750mA, T_J=25^{\circ}C$         |      |      | 50   | mV             |
| Quiescent Current        | $I_q$                 | $T_J=25^{\circ}C$                          |      | 3.5  | 8    | mA             |
| Quiescent Current Change | $\Delta I_q$          | $8V \leq V_i \leq 25V$                     |      |      | 1.3  | mA             |
|                          |                       | $5mA \leq I_o \leq 1A$                     |      |      | 0.5  | mA             |
| Output Noise Voltage     | $V_N$                 | $10Hz \leq f \leq 100KHz, T_J=25^{\circ}C$ |      | 10   |      | $\mu V/V_o$    |
| Output voltage drift     | $\Delta V_o/\Delta T$ | $I_o=5mA$                                  |      | -0.3 |      | $mV/^{\circ}C$ |
| Ripple Rejection         | RR                    | $8V \leq V_i \leq 18V, f=120Hz$            |      | 68   |      | dB             |
| Dropout Voltage          | $V_d$                 | $I_o=1A, T_J=25^{\circ}C$                  |      | 2    |      | V              |
| Short Circuit Current    | $I_{sc}$              | $T_J=25^{\circ}C$                          |      | 200  |      | mA             |

\* Pulse test.

**TYPICAL APPLICATION**

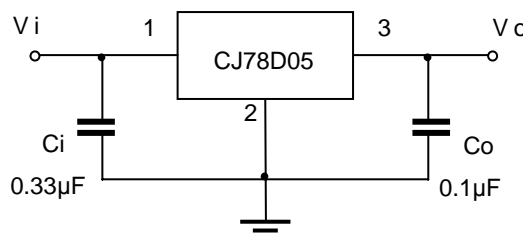

# Typical Characteristics

**Output Characteristics**

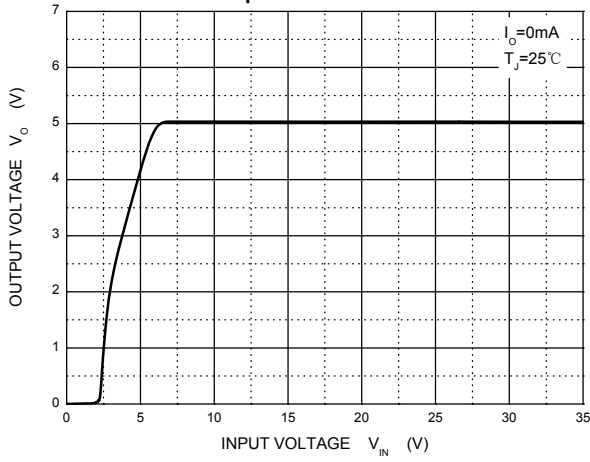

**Dropout Characteristics**

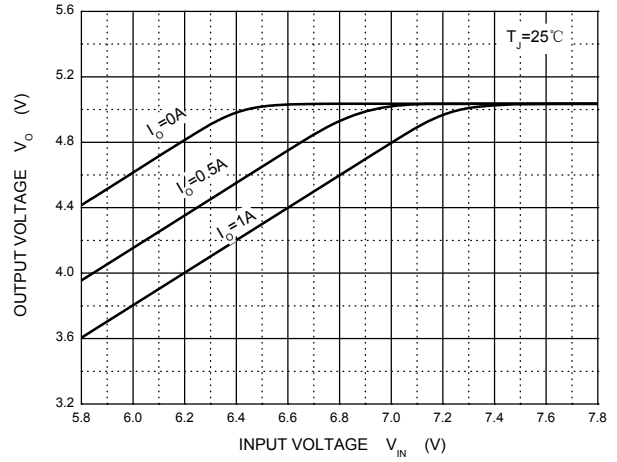

**Quiescent Current**

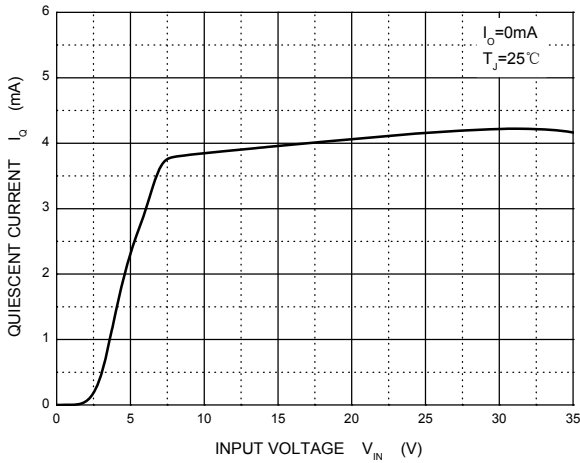

**Current Cut-off Grid Voltage**

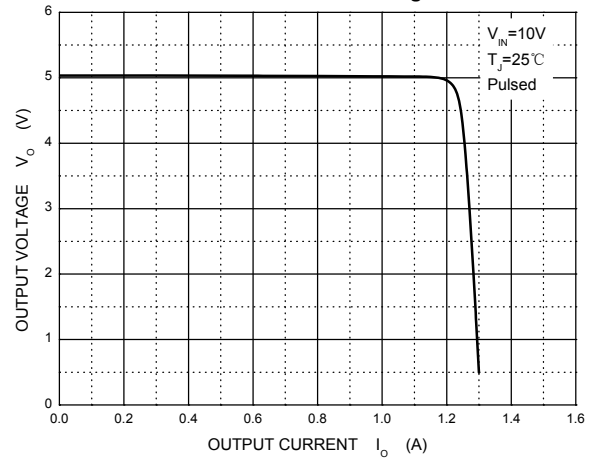

**Output Voltage vs Junction Temperature**

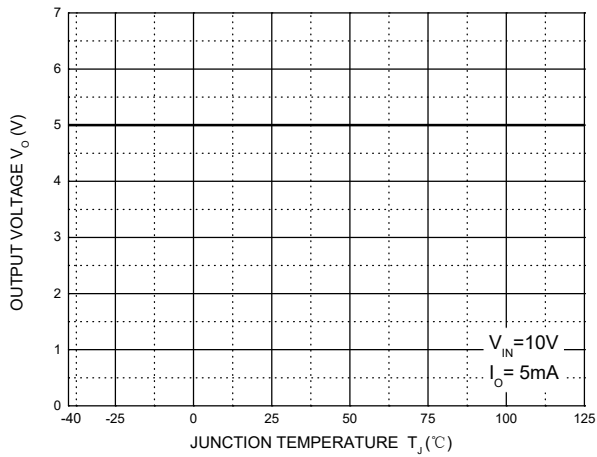

**Power Derating Curve**

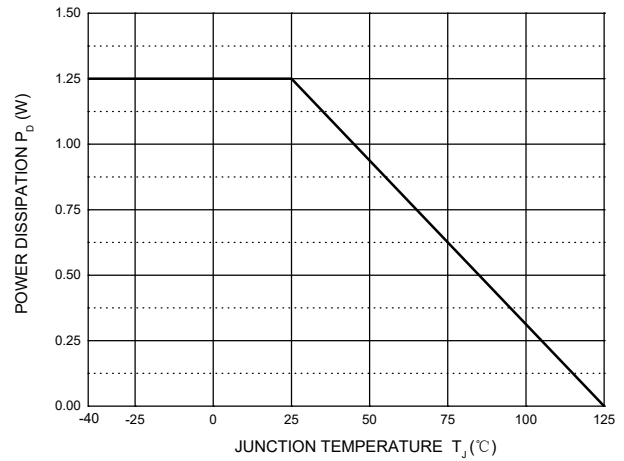

## TO-252-2L Package Outline Dimensions

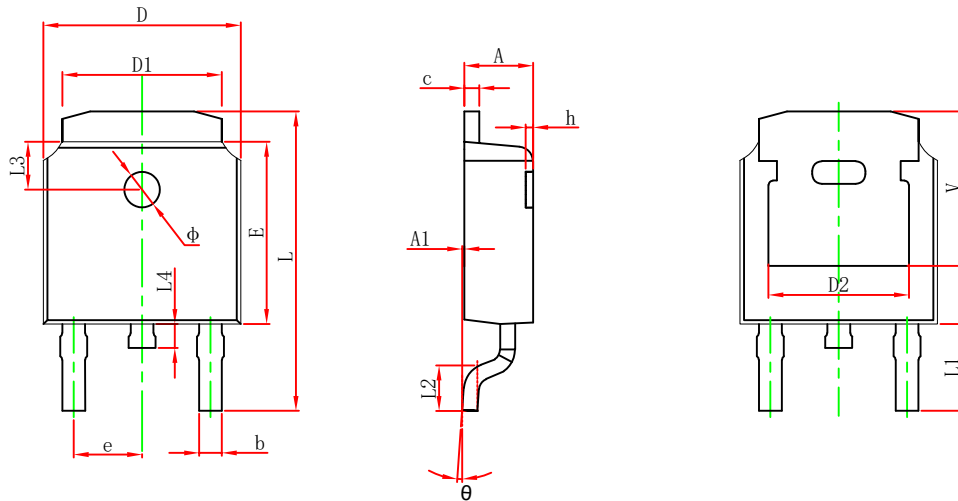

| Symbol   | Dimensions In Millimeters |        | Dimensions In Inches |       |
|----------|---------------------------|--------|----------------------|-------|
|          | Min.                      | Max.   | Min.                 | Max.  |
| A        | 2.200                     | 2.400  | 0.087                | 0.094 |
| A1       | 0.000                     | 0.127  | 0.000                | 0.005 |
| b        | 0.635                     | 0.770  | 0.025                | 0.030 |
| c        | 0.460                     | 0.580  | 0.018                | 0.023 |
| D        | 6.500                     | 6.700  | 0.256                | 0.264 |
| D1       | 5.100                     | 5.460  | 0.201                | 0.215 |
| D2       | 4.830 REF.                |        | 0.190 REF.           |       |
| E        | 6.000                     | 6.200  | 0.236                | 0.244 |
| e        | 2.186                     | 2.386  | 0.086                | 0.094 |
| L        | 9.712                     | 10.312 | 0.382                | 0.406 |
| L1       | 2.900 REF.                |        | 0.114 REF.           |       |
| L2       | 1.400                     | 1.700  | 0.055                | 0.067 |
| L3       | 1.600 REF.                |        | 0.063 REF.           |       |
| L4       | 0.600                     | 1.000  | 0.024                | 0.039 |
| $\Phi$   | 1.100                     | 1.300  | 0.043                | 0.051 |
| $\theta$ | 0°                        | 8°     | 0°                   | 8°    |
| h        | 0.000                     | 0.300  | 0.000                | 0.012 |
| V        | 5.250 REF.                |        | 0.207 REF.           |       |

## TO-252-2L Suggested Pad Layout

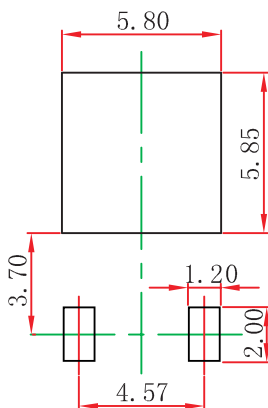

**Note:**

1. Controlling dimension: in millimeters.
2. General tolerance:  $\pm 0.05\text{mm}$ .
3. The pad layout is for reference purposes only.

# TO-252-2L Tape and Reel

## TO-252 Embossed Carrier Tape

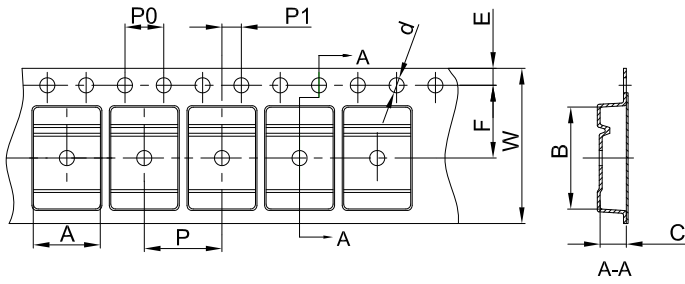

**Packaging Description:**  
 TO-252 parts are shipped in tape. The carrier tape is made from a dissipative (carbon filled) polycarbonate resin. The cover tape is a multilayer film (Heat Activated Adhesive in nature) primarily composed of polyester film, adhesive layer, sealant, and anti-static sprayed agent. These reeled parts in standard option are shipped with 25,00 units per 13" or 33.0 cm diameter reel. The reels are clear in color and is made of polystyrene plastic (anti-static coated).

Dimensions are in millimeter

| Pkg type | A    | B     | C    | d     | E    | F    | P0   | P    | P1   | W     |
|----------|------|-------|------|-------|------|------|------|------|------|-------|
| TO-252   | 6.90 | 10.50 | 2.70 | Ø1.55 | 1.75 | 7.50 | 4.00 | 8.00 | 2.00 | 16.00 |

## TO-252 Tape Leader and Trailer

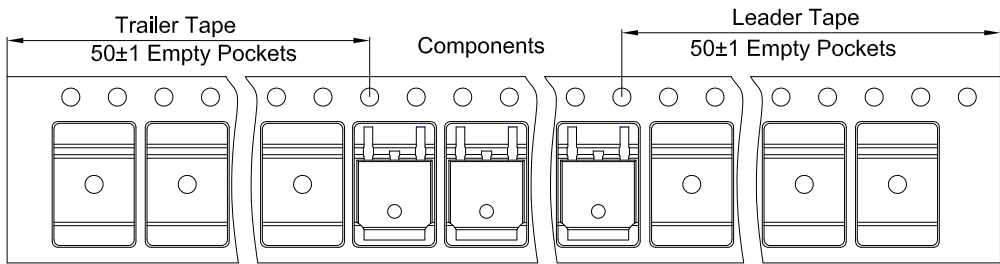

## TO-252 Reel

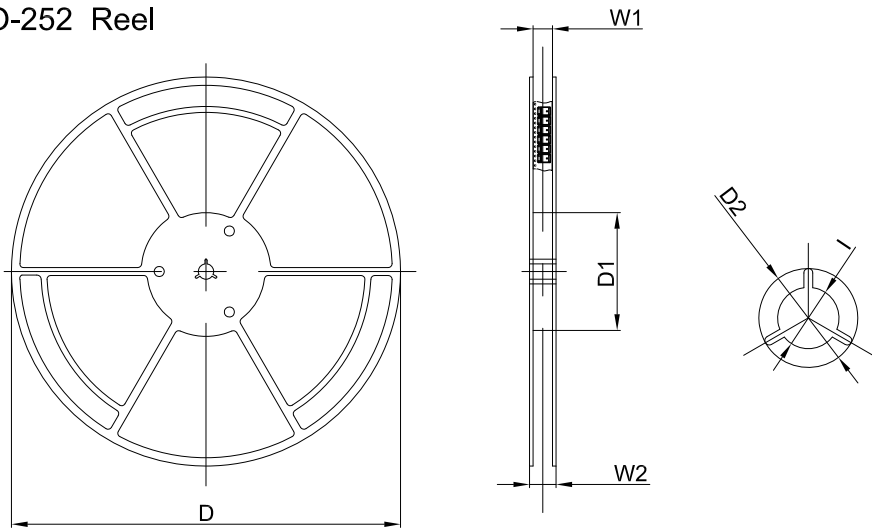

Dimensions are in millimeter

| Reel Option | D      | D1     | D2     | W1    | W2    | I      |
|-------------|--------|--------|--------|-------|-------|--------|
| 13" Dia     | 330.00 | 100.00 | Ø21.00 | 16.40 | 21.00 | Ø13.00 |

| REEL      | Reel Size | Box       | Box Size(mm) | Carton     | Carton Size(mm) | G.W.(kg) |
|-----------|-----------|-----------|--------------|------------|-----------------|----------|
| 2,500 pcs | 13inch    | 2,500 pcs | 340×336×29   | 25,000 pcs | 353×346×365     |          |

# DISCLAIMER

## **IMPORTANT NOTICE, PLEASE READ CAREFULLY**

The information in this data sheet is intended to describe the operation and characteristics of our products. JSCJ has the right to make any modification, enhancement, improvement, correction or other changes to any content in this data sheet, including but not limited to specification parameters, circuit design and application information, without prior notice.

Any person who purchases or uses JSCJ products for design shall: 1. Select products suitable for circuit application and design; 2. Design, verify and test the rationality of circuit design; 3. Procedures to ensure that the design complies with relevant laws and regulations and the requirements of such laws and regulations. JSCJ makes no warranty or representation as to the accuracy or completeness of the information contained in this data sheet and assumes no responsibility for the application or use of any of the products described in this data sheet.

Without the written consent of JSCJ, this product shall not be used in occasions requiring high quality or high reliability, including but not limited to the following occasions: medical equipment, automotive electronics, military facilities and aerospace. JSCJ shall not be responsible for casualties or property losses caused by abnormal use or application of this product.

Official Website: [www.jscj-elec.com](http://www.jscj-elec.com)

Copyright © JIANGSU CHANGJING ELECTRONICS TECHNOLOGY CO., LTD.